

# ***RED-D-ARC*** ***FX450***

IM10094

February, 2011

For use with machines having Code Numbers: **11789**

# **Red-D-Arc Welderrentals®**

## ***OPERATOR'S MANUAL***

### ***Red-D-Arc Spec-Built Welding Equipment***

This **RED-D-ARC** welder is built to **RED-D-ARC Extreme Duty** design specifications by Lincoln Electric.

### ***Safety Depends on You***

This welder is designed and built with safety in mind.  
However, your overall safety can be increased by proper installation  
... and thoughtful operation on your part.

**DO NOT INSTALL, OPERATE OR REPAIR THIS EQUIPMENT  
WITHOUT READING THIS MANUAL AND THE SAFETY  
PRECAUTIONS CONTAINED THROUGHOUT.**

And, most importantly, think before you act and be careful.

**reddarc.com**

**Airgas®**

***North America's Largest Fleet of Welding Equipment***

## ⚠ WARNING

### ⚠ CALIFORNIA PROPOSITION 65 WARNINGS ⚠

Diesel engine exhaust and some of its constituents are known to the State of California to cause cancer, birth defects, and other reproductive harm.

The Above For Diesel Engines

The engine exhaust from this product contains chemicals known to the State of California to cause cancer, birth defects, or other reproductive harm.

The Above For Gasoline Engines

**ARC WELDING CAN BE HAZARDOUS. PROTECT YOURSELF AND OTHERS FROM POSSIBLE SERIOUS INJURY OR DEATH. KEEP CHILDREN AWAY. PACEMAKER WEARERS SHOULD CONSULT WITH THEIR DOCTOR BEFORE OPERATING.**

Read and understand the following safety highlights. For additional safety information, it is strongly recommended that you purchase a copy of "Safety in Welding & Cutting - ANSI Standard Z49.1" from the American Welding Society, P.O. Box 351040, Miami, Florida 33135 or CSA Standard W117.2-1974. A Free copy of "Arc Welding Safety" booklet E205 is available from the Lincoln Electric Company, 22801 St. Clair Avenue, Cleveland, Ohio 44117-1199.

**BE SURE THAT ALL INSTALLATION, OPERATION, MAINTENANCE AND REPAIR PROCEDURES ARE PERFORMED ONLY BY QUALIFIED INDIVIDUALS.**



### FOR ENGINE powered equipment.

1.a. Turn the engine off before troubleshooting and maintenance work unless the maintenance work requires it to be running.



1.b. Operate engines in open, well-ventilated areas or vent the engine exhaust fumes outdoors.



1.c. Do not add the fuel near an open flame welding arc or when the engine is running. Stop the engine and allow it to cool before refueling to prevent spilled fuel from vaporizing on contact with hot engine parts and igniting. Do not spill fuel when filling tank. If fuel is spilled, wipe it up and do not start engine until fumes have been eliminated.

1.d. Keep all equipment safety guards, covers and devices in position and in good repair. Keep hands, hair, clothing and tools away from V-belts, gears, fans and all other moving parts when starting, operating or repairing equipment.

1.e. In some cases it may be necessary to remove safety guards to perform required maintenance. Remove guards only when necessary and replace them when the maintenance requiring their removal is complete. Always use the greatest care when working near moving parts.



1.f. Do not put your hands near the engine fan. Do not attempt to override the governor or idler by pushing on the throttle control rods while the engine is running.

1.g. To prevent accidentally starting gasoline engines while turning the engine or welding generator during maintenance work, disconnect the spark plug wires, distributor cap or magneto wire as appropriate.



1.h. To avoid scalding, do not remove the radiator pressure cap when the engine is hot.



### ELECTRIC AND MAGNETIC FIELDS may be dangerous

2.a. Electric current flowing through any conductor causes localized Electric and Magnetic Fields (EMF). Welding current creates EMF fields around welding cables and welding machines

2.b. EMF fields may interfere with some pacemakers, and welders having a pacemaker should consult their physician before welding.

2.c. Exposure to EMF fields in welding may have other health effects which are now not known.

2.d. All welders should use the following procedures in order to minimize exposure to EMF fields from the welding circuit:

2.d.1. Route the electrode and work cables together - Secure them with tape when possible.

2.d.2. Never coil the electrode lead around your body.

2.d.3. Do not place your body between the electrode and work cables. If the electrode cable is on your right side, the work cable should also be on your right side.

2.d.4. Connect the work cable to the workpiece as close as possible to the area being welded.

2.d.5. Do not work next to welding power source.



## ELECTRIC SHOCK can kill.

3.a. The electrode and work (or ground) circuits are electrically “hot” when the welder is on. Do not touch these “hot” parts with your bare skin or wet clothing. Wear dry, hole-free gloves to insulate hands.

3.b. Insulate yourself from work and ground using dry insulation. Make certain the insulation is large enough to cover your full area of physical contact with work and ground.

**In addition to the normal safety precautions, if welding must be performed under electrically hazardous conditions (in damp locations or while wearing wet clothing; on metal structures such as floors, gratings or scaffolds; when in cramped positions such as sitting, kneeling or lying, if there is a high risk of unavoidable or accidental contact with the workpiece or ground) use the following equipment:**

- Semiautomatic DC Constant Voltage (Wire) Welder.
- DC Manual (Stick) Welder.
- AC Welder with Reduced Voltage Control.

3.c. In semiautomatic or automatic wire welding, the electrode, electrode reel, welding head, nozzle or semiautomatic welding gun are also electrically “hot”.

3.d. Always be sure the work cable makes a good electrical connection with the metal being welded. The connection should be as close as possible to the area being welded.

3.e. Ground the work or metal to be welded to a good electrical (earth) ground.

3.f. Maintain the electrode holder, work clamp, welding cable and welding machine in good, safe operating condition. Replace damaged insulation.

3.g. Never dip the electrode in water for cooling.

3.h. Never simultaneously touch electrically “hot” parts of electrode holders connected to two welders because voltage between the two can be the total of the open circuit voltage of both welders.

3.i. When working above floor level, use a safety belt to protect yourself from a fall should you get a shock.

3.j. Also see Items 6.c. and 8.



## ARC RAYS can burn.

4.a. Use a shield with the proper filter and cover plates to protect your eyes from sparks and the rays of the arc when welding or observing open arc welding. Headshield and filter lens should conform to ANSI Z87.1 standards.

4.b. Use suitable clothing made from durable flame-resistant material to protect your skin and that of your helpers from the arc rays.

4.c. Protect other nearby personnel with suitable, non-flammable screening and/or warn them not to watch the arc nor expose themselves to the arc rays or to hot spatter or metal.



## FUMES AND GASES can be dangerous.

5.a. Welding may produce fumes and gases hazardous to health. Avoid breathing these fumes and gases. When welding, keep your head out of the fume. Use enough ventilation and/or exhaust at the arc to keep

fumes and gases away from the breathing zone. **When welding with electrodes which require special ventilation such as stainless or hard facing (see instructions on container or MSDS) or on lead or cadmium plated steel and other metals or coatings which produce highly toxic fumes, keep exposure as low as possible and within applicable OSHA PEL and ACGIH TLV limits using local exhaust or mechanical ventilation. In confined spaces or in some circumstances, outdoors, a respirator may be required. Additional precautions are also required when welding on galvanized steel.**

5. b. The operation of welding fume control equipment is affected by various factors including proper use and positioning of the equipment, maintenance of the equipment and the specific welding procedure and application involved. Worker exposure level should be checked upon installation and periodically thereafter to be certain it is within applicable OSHA PEL and ACGIH TLV limits.

5.c. Do not weld in locations near chlorinated hydrocarbon vapors coming from degreasing, cleaning or spraying operations. The heat and rays of the arc can react with solvent vapors to form phosgene, a highly toxic gas, and other irritating products.

5.d. Shielding gases used for arc welding can displace air and cause injury or death. Always use enough ventilation, especially in confined areas, to insure breathing air is safe.

5.e. Read and understand the manufacturer’s instructions for this equipment and the consumables to be used, including the material safety data sheet (MSDS) and follow your employer’s safety practices. MSDS forms are available from your welding distributor or from the manufacturer.

5.f. Also see item 1.b.

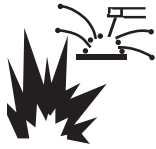

## WELDING and CUTTING SPARKS can cause fire or explosion.

6.a. Remove fire hazards from the welding area. If this is not possible, cover them to prevent the welding sparks from starting a fire.

Remember that welding sparks and hot materials from welding can easily go through small cracks and openings to adjacent areas. Avoid welding near hydraulic lines. Have a fire extinguisher readily available.

- 6.b. Where compressed gases are to be used at the job site, special precautions should be used to prevent hazardous situations. Refer to "Safety in Welding and Cutting" (ANSI Standard Z49.1) and the operating information for the equipment being used.
- 6.c. When not welding, make certain no part of the electrode circuit is touching the work or ground. Accidental contact can cause overheating and create a fire hazard.
- 6.d. Do not heat, cut or weld tanks, drums or containers until the proper steps have been taken to insure that such procedures will not cause flammable or toxic vapors from substances inside. They can cause an explosion even though they have been "cleaned". For information, purchase "Recommended Safe Practices for the Preparation for Welding and Cutting of Containers and Piping That Have Held Hazardous Substances", AWS F4.1 from the American Welding Society (see address above).
- 6.e. Vent hollow castings or containers before heating, cutting or welding. They may explode.
- 6.f. Sparks and spatter are thrown from the welding arc. Wear oil free protective garments such as leather gloves, heavy shirt, cuffless trousers, high shoes and a cap over your hair. Wear ear plugs when welding out of position or in confined places. Always wear safety glasses with side shields when in a welding area.
- 6.g. Connect the work cable to the work as close to the welding area as practical. Work cables connected to the building framework or other locations away from the welding area increase the possibility of the welding current passing through lifting chains, crane cables or other alternate circuits. This can create fire hazards or overheat lifting chains or cables until they fail.
- 6.h. Also see item 1.c.
- 6.i. Read and follow NFPA 51B "Standard for Fire Prevention During Welding, Cutting and Other Hot Work", available from NFPA, 1 Batterymarch Park, PO box 9101, Quincy, Ma 022690-9101.
- 6.j. Do not use a welding power source for pipe thawing.



## CYLINDER may explode if damaged.

7.a. Use only compressed gas cylinders containing the correct shielding gas for the process used and properly operating regulators designed for the gas and pressure used. All hoses, fittings, etc. should be suitable for the application and maintained in good condition.

- 7.b. Always keep cylinders in an upright position securely chained to an undercarriage or fixed support.
- 7.c. Cylinders should be located:
  - Away from areas where they may be struck or subjected to physical damage.
  - A safe distance from arc welding or cutting operations and any other source of heat, sparks, or flame.
- 7.d. Never allow the electrode, electrode holder or any other electrically "hot" parts to touch a cylinder.
- 7.e. Keep your head and face away from the cylinder valve outlet when opening the cylinder valve.
- 7.f. Valve protection caps should always be in place and hand tight except when the cylinder is in use or connected for use.
- 7.g. Read and follow the instructions on compressed gas cylinders, associated equipment, and CGA publication P-1, "Precautions for Safe Handling of Compressed Gases in Cylinders," available from the Compressed Gas Association 1235 Jefferson Davis Highway, Arlington, VA 22202.



## FOR ELECTRICALLY powered equipment.

- 8.a. Turn off input power using the disconnect switch at the fuse box before working on the equipment.
- 8.b. Install equipment in accordance with the U.S. National Electrical Code, all local codes and the manufacturer's recommendations.
- 8.c. Ground the equipment in accordance with the U.S. National Electrical Code and the manufacturer's recommendations.

Refer to <http://www.lincolnelectric.com/safety> for additional safety information.

## PRÉCAUTIONS DE SÛRETÉ

Pour votre propre protection lire et observer toutes les instructions et les précautions de sûreté spécifiques qui paraissent dans ce manuel aussi bien que les précautions de sûreté générales suivantes:

### Sûreté Pour Soudage A L'Arc

1. Protégez-vous contre la secousse électrique:
  - a. Les circuits à l'électrode et à la pièce sont sous tension quand la machine à souder est en marche. Eviter toujours tout contact entre les parties sous tension et la peau nue ou les vêtements mouillés. Porter des gants secs et sans trous pour isoler les mains.
  - b. Faire très attention de bien s'isoler de la masse quand on soude dans des endroits humides, ou sur un plancher métallique ou des grilles métalliques, principalement dans les positions assis ou couché pour lesquelles une grande partie du corps peut être en contact avec la masse.
  - c. Maintenir le porte-électrode, la pince de masse, le câble de soudage et la machine à souder en bon et sûr état de fonctionnement.
  - d. Ne jamais plonger le porte-électrode dans l'eau pour le refroidir.
  - e. Ne jamais toucher simultanément les parties sous tension des porte-électrodes connectés à deux machines à souder parce que la tension entre les deux pinces peut être le total de la tension à vide des deux machines.
  - f. Si on utilise la machine à souder comme une source de courant pour soudage semi-automatique, ces précautions pour le porte-électrode s'appliquent aussi au pistolet de soudage.
2. Dans le cas de travail au dessus du niveau du sol, se protéger contre les chutes dans le cas où on recoit un choc. Ne jamais enrouler le câble-électrode autour de n'importe quelle partie du corps.
3. Un coup d'arc peut être plus sévère qu'un coup de soliel, donc:
  - a. Utiliser un bon masque avec un verre filtrant approprié ainsi qu'un verre blanc afin de se protéger les yeux du rayonnement de l'arc et des projections quand on soude ou quand on regarde l'arc.
  - b. Porter des vêtements convenables afin de protéger la peau de soudeur et des aides contre le rayonnement de l'arc.
  - c. Protéger l'autre personnel travaillant à proximité au soudage à l'aide d'écrans appropriés et non-inflammables.
4. Des gouttes de laitier en fusion sont émises de l'arc de soudage. Se protéger avec des vêtements de protection libres de l'huile, tels que les gants en cuir, chemise épaisse, pantalons sans revers, et chaussures montantes.
5. Toujours porter des lunettes de sécurité dans la zone de soudage. Utiliser des lunettes avec écrans latéraux dans les zones où l'on pique le laitier.

6. Eloigner les matériaux inflammables ou les recouvrir afin de prévenir tout risque d'incendie dû aux étincelles.
7. Quand on ne soude pas, poser la pince à un endroit isolé de la masse. Un court-circuit accidentel peut provoquer un échauffement et un risque d'incendie.
8. S'assurer que la masse est connectée le plus près possible de la zone de travail qu'il est pratique de le faire. Si on place la masse sur la charpente de la construction ou d'autres endroits éloignés de la zone de travail, on augmente le risque de voir passer le courant de soudage par les chaînes de levage, câbles de grue, ou autres circuits. Cela peut provoquer des risques d'incendie ou d'échauffement des chaînes et des câbles jusqu'à ce qu'ils se rompent.
9. Assurer une ventilation suffisante dans la zone de soudage. Ceci est particulièrement important pour le soudage de tôles galvanisées plombées, ou cadmiées ou tout autre métal qui produit des fumeés toxiques.
10. Ne pas souder en présence de vapeurs de chlore provenant d'opérations de dégraissage, nettoyage ou pistolage. La chaleur ou les rayons de l'arc peuvent réagir avec les vapeurs du solvant pour produire du phosgène (gas fortement toxique) ou autres produits irritants.
11. Pour obtenir de plus amples renseignements sur la sûreté, voir le code "Code for safety in welding and cutting" CSA Standard W 117.2-1974.

## PRÉCAUTIONS DE SÛRETÉ POUR LES MACHINES À SOUDER À TRANSFORMATEUR ET À REDRESSEUR

1. Relier à la terre le chassis du poste conformément au code de l'électricité et aux recommandations du fabricant. Le dispositif de montage ou la pièce à souder doit être branché à une bonne mise à la terre.
2. Autant que possible, l'installation et l'entretien du poste seront effectués par un électricien qualifié.
3. Avant de faire des travaux à l'intérieur de poste, la débrancher à l'interrupteur à la boîte de fusibles.
4. Garder tous les couvercles et dispositifs de sûreté à leur place.

# Thank You

for selecting one of our **QUALITY** products. We want you to take pride in operating this product ... as much pride as we have in bringing this product to you!

## CUSTOMER ASSISTANCE POLICY

The business of our company is manufacturing and selling high quality welding equipment. Our challenge is to meet the needs of our customers and to exceed their expectations. On occasion, purchasers may ask us for advice or information about their use of our products. We respond to our customers based on the best information in our possession at that time. We are not in a position to warrant or guarantee such advice, and assume no liability, with respect to such information or advice. We expressly disclaim any warranty of any kind, including any warranty of fitness for any customer's particular purpose, with respect to such information or advice. As a matter of practical consideration, we also cannot assume any responsibility for updating or correcting any such information or advice once it has been given, nor does the provision of information or advice create, expand or alter any warranty with respect to the sale of our products.

We are a responsive manufacturer, but the selection and use of specific products sold by us is solely within the control of, and remains the sole responsibility of the customer. Many variables beyond our control affect the results obtained in applying these types of fabrication methods and service requirements.

Subject to Change – This information is accurate to the best of our knowledge at the time of printing.

## **Please Examine Carton and Equipment For Damage Immediately**

When this equipment is shipped, title passes to the purchaser upon receipt by the carrier. Consequently, Claims for material damaged in shipment must be made by the purchaser against the transportation company at the time the shipment is received.

Please record your equipment identification information below for future reference. This information can be found on your machine nameplate.

Product \_\_\_\_\_

Model Number \_\_\_\_\_

Code Number or Date Code (if available) \_\_\_\_\_

Serial Number (if available) \_\_\_\_\_

Date Purchased \_\_\_\_\_

Where Purchased \_\_\_\_\_

Whenever you request replacement parts or information on this equipment, always supply the information you have recorded above.

**Read this Operators Manual completely** before attempting to use this equipment. Save this manual and keep it handy for quick reference. Pay particular attention to the safety instructions we have provided for your protection. The level of seriousness to be applied to each is explained below:

### **⚠ WARNING**

This statement appears where the information **must** be followed **exactly** to avoid **serious personal injury** or **loss of life**.

### **⚠ CAUTION**

This statement appears where the information **must** be followed to avoid **minor personal injury** or **damage to this equipment**.



<b>Installation .....</b>	<b>Section A</b>
Technical Specifications .....	A-1
Welding Process, Physical Dimensions .....	A-2
Safety Precautions .....	A-3
Select Suitable Location.....	A-3
Lifting.....	A-3
Stacking .....	A-3
Environmental Limitations .....	A-3
Input and Grounding Connections .....	A-3
High Frequency Protection .....	A-3
Input Connection .....	A-4
Input Fuse and Supply Wire Considerations.....	A-4
Input Voltage Selection .....	A-4
Cable Connections.....	A-5
Recommended Electrode and Work Cable for arc Welding .....	A-6
Output Cable Guidelines.....	A-6
<hr/>	
<b>Operation .....</b>	<b>Section B</b>
Safety Precautions .....	B-1
Graphic Symbols.....	B-1, B-2
Product Description .....	B-2
Duty Cycle .....	B-2
Design Features .....	B-2
Recommended Processes and Equipment .....	B-3
Case Front Controls.....	B-4
Power-Up Sequence.....	B-5
Case Back Controls .....	B-5
Common Welding Procedures, Weld Controls and Displays.....	B-5, thru B-8
<hr/>	
<b>Accessories .....</b>	<b>Section C</b>
Options / Accessories.....	C-1
<hr/>	
<b>Maintenance .....</b>	<b>Section D</b>
Safety Precautions .....	D-1
VISUAL INSPECTION.....	D-1
ROUTINE MAINTENANCE .....	D-1
PERIODIC MAINTENANCE .....	D-1
<hr/>	
<b>Section E .....</b>	<b>Troubleshooting</b>
Safety Precautions.....	E-1
How to Use Troubleshooting Guide.....	E-1
Troubleshooting Guide .....	E-2
Error Codes .....	E-3
<hr/>	
<b>Wiring Diagram and Dimension Print .....</b>	<b>Section F</b>
<hr/>	
<b>Parts List .....</b>	<b>P-678 Series</b>
<hr/>	

## TECHNICAL SPECIFICATIONS - FX450

POWER SOURCE-INPUT VOLTAGE AND CURRENT					
Model	Duty Cycle	Input Voltage $\pm$ 10%	Input Amperes	Idle Power	Power Factor @ Rated Output
K3073-1	60% rating	380 / 460 / 575 / 3 / 50 / 60	37 / 27 / 22	72 Watts Max. (fan on)	95%
	100% rating		29 / 21 / 17		
RATED OUTPUT					
Process	Duty Cycle	Volts at Rated Amperes		Amperes	
GMAW (CV)	60%	36.5V		450	
	100%	34V		400	
GTAW (CC)	60%	28V		450	
	100%	26V		400	
SMAW (CC)	60%	38V		450	
	100%	36V		400	
FCAW-GS (CV)	60%	36.5V		450	
	100%	34V		400	
FCAW-SS (CV)	60%	36.5V		450	
	100%	34V		400	
RECOMMENDED INPUT WIRE AND FUSE SIZES <sup>(1)</sup>					
VOLTAGE 50/60Hz	Maximum Input Amperes	Cord Size <sup>(3)</sup> AWG SIZES (mm)	Type 75°C Copper Wire in Conduit AWG (mm <sup>2</sup> )	COPPER GROUNDING CONDUCTOR AWG (mm <sup>2</sup> )	Fuse (Super Lag) or Breaker Size <sup>(2)</sup>
380/3/50	42 A	8(10)	8 (10)	10 (6)	50
460/3/60	30 A	8(10)	10 (6)	10 (6)	45
575/3/60	25 A	10(6)	12 (4)	12 (4)	35

(1) Cord and Fuse Sizes based upon the U.S. National Electric Code and maximum output for 40°C (104°) ambient.

(2) Also called "inverse time" or "thermal/magnetic" circuit breakers; circuit breakers that have a delay in tripping action that decreases as the magnitude of current increases.

(3) Type SD cord or similar in 30°C ambient.

FX450 (RED-D-ARC)

Red-D-Arc  
Welderrentals.



<b>WELDING PROCESS</b>				
<b>PROCESS</b>	<b>OUTPUT RANGE (AMPERES)</b>		<b>OCV (U<sub>o</sub>)</b>	
GMAW (CV)	40-500		60	
GTAW (CC)	10-500		24	
SMAW (CC)	15-500		60	
FCAW-GS (CV)	40-500		60	
FCAW-SS (CV)	40-500		60	
<b>PHYSICAL DIMENSIONS</b>				
<b>MODEL</b>	<b>HEIGHT</b>	<b>WIDTH</b>	<b>DEPTH</b>	<b>WEIGHT</b>
K3073-1	18.80in (478mm)	14.14in (359mm)	26.66in (677mm)	125lbs (56.6kg)*
<b>TEMPERATURE RANGES</b>				
<b>OPERATING TEMPERATURE RANGE</b>		<b>STORAGE TEMPERATURE RANGE</b>		
Environmentally Hardened: 14°F to 131°F (-10°C to 55°C **)		Environmentally Hardened: -40°F to 185°F (-40°C to 85°C)		

**IP23 155°F Insulation Class**

\* Weight does not include input cord.

\*\* Output De-rated at Temperatures above 40°C.

## SAFETY PRECAUTIONS

**⚠ WARNING**

**ELECTRIC SHOCK** can kill.

**ONLY QUALIFIED PERSONNEL SHOULD PERFORM THIS INSTALLATION.**

- **TURN OFF INPUT POWER TO THE POWER SOURCE AT THE DISCONNECT SWITCH OR FUSE BOX BEFORE WORKING ON THIS EQUIPMENT. TURN OFF THE INPUT POWER TO ANY OTHER EQUIPMENT CONNECTED TO THE WELDING SYSTEM AT THE DISCONNECT SWITCH OR FUSE BOX BEFORE WORKING ON THE EQUIPMENT.**
- **DO NOT TOUCH ELECTRICALLY HOT PARTS.**
- **ALWAYS CONNECT THE FX450 GROUNDING LUG (LOCATED INSIDE THE RECONNECT INPUT ACCESS DOOR) TO A PROPER SAFETY (EARTH) GROUND.**

## SELECT SUITABLE LOCATION

**LOCATION AND VENTILATION FOR COOLING**

Place the welder where clean cooling air can freely circulate in through the rear louvers and out through the case sides. Dirt, dust, or any foreign material that can be drawn into the welder should be kept at a minimum. Failure to observe these precautions can result in excessive operating temperatures and nuisance shutdowns.

**LIFTING**

Both handles should be used when lifting the FX450. When using a crane or overhead device a lifting strap should be connected to both handles. Do not attempt to lift the FX450 with accessories attached to it.

**STACKING**

The FX450 cannot be stacked.

**ENVIRONMENTAL LIMITATIONS**

The FX450 is IP23 rated for use in an outdoor environment. The FX450 should not be subjected to falling water during use nor should any parts of it be submerged in water. Doing so may cause improper operation as well as pose a safety hazard. The best practice is to keep the machine in a dry, sheltered area.

**⚠ CAUTION**

Do not mount the FX450 over combustible surfaces. Where there is a combustible surface directly under stationary or fixed electrical equipment, that surface shall be covered with a steel plate at least .060" (1.6mm) thick, which shall extend not less than 5.90" (150mm) beyond the equipment on all sides.

## INPUT AND GROUNDING CONNECTIONS

**MACHINE GROUNDING**

The frame of the welder must be grounded. A ground terminal marked with the symbol shown is located inside the reconnect/input connection area for this purpose. See your local and national electrical codes for proper grounding methods.

**HIGH FREQUENCY PROTECTION**

Locate the FX450 away from radio controlled machinery. The normal operation of the FX450 may adversely affect the operation of RF controlled equipment, which may result in bodily injury or damage to the equipment.

**HIGH TEMPERATURE OPERATION****WELDER OUTPUT RATINGS AT 55°C ELEVATED TEMPERATURES**

AMPS	DUTY CYCLE	VOLTS	TEMPERATURES
340	100%	34VDC	55°C
375	60%	35VDC	
400	40%	36VDC	
450	20%	38VDC	

**⚠ WARNING****ELECTRIC SHOCK** can kill.

**ONLY A QUALIFIED ELECTRICIAN SHOULD CONNECT THE INPUT LEADS TO THE FX450. CONNECTIONS SHOULD BE MADE IN ACCORDANCE WITH ALL LOCAL AND NATIONAL ELECTRICAL CODES AND THE CONNECTION DIAGRAM LOCATED ON THE INSIDE OF THE RECONNECT/INPUT ACCESS DOOR OF THE MACHINE. FAILURE TO DO SO MAY RESULT IN BODILY INJURY OR DEATH.**

**INPUT CONNECTION**

(See Figure A.1)

Use a three-phase supply line. A 1.40 inch (36 mm) diameter access hole for the input supply is located on the case back. Connect L1, L2, L3 and ground according to the Input Supply Connection Diagram decal located on the internal horizontal panel.

To access the reconnect/input supply connection blocks, remove the 8 screws that secure the case top of the welder and remove the case top.

**INPUT FUSE AND SUPPLY WIRE CONSIDERATIONS**

Refer to Specification in this Installation Section for recommended fuse, wire sizes and type of the copper wires. Fuse the input circuit with the recommended super lag fuse or delay type breakers (also called "inverse time" or "thermal/magnetic" circuit breakers). Choose input and grounding wire size according to local or national electrical codes. Using input wire sizes, fuses or circuit breakers smaller than recommended may result in "nuisance" shut-offs from welder inrush currents, even if the machine is not being used at high currents.

**INPUT VOLTAGE SELECTION**

Welders are shipped connected for 460 Volt input voltage. To move this connection to a different input voltage, see the diagram located on the inside panel in the reconnect/input connection area, also illustrated below. If the Auxiliary lead (indicated as 'A') is placed in the wrong position and power is applied to the machine, the machine will protect itself and display an error message:

- "Err" "058" will be shown on the display.
- The control board and switch boards will blink out error 58 on their status leds.
- The weld output will be turned off and the control board will force itself into an idle state.
- The machine will need to have the misconnect condition removed before it will recover.

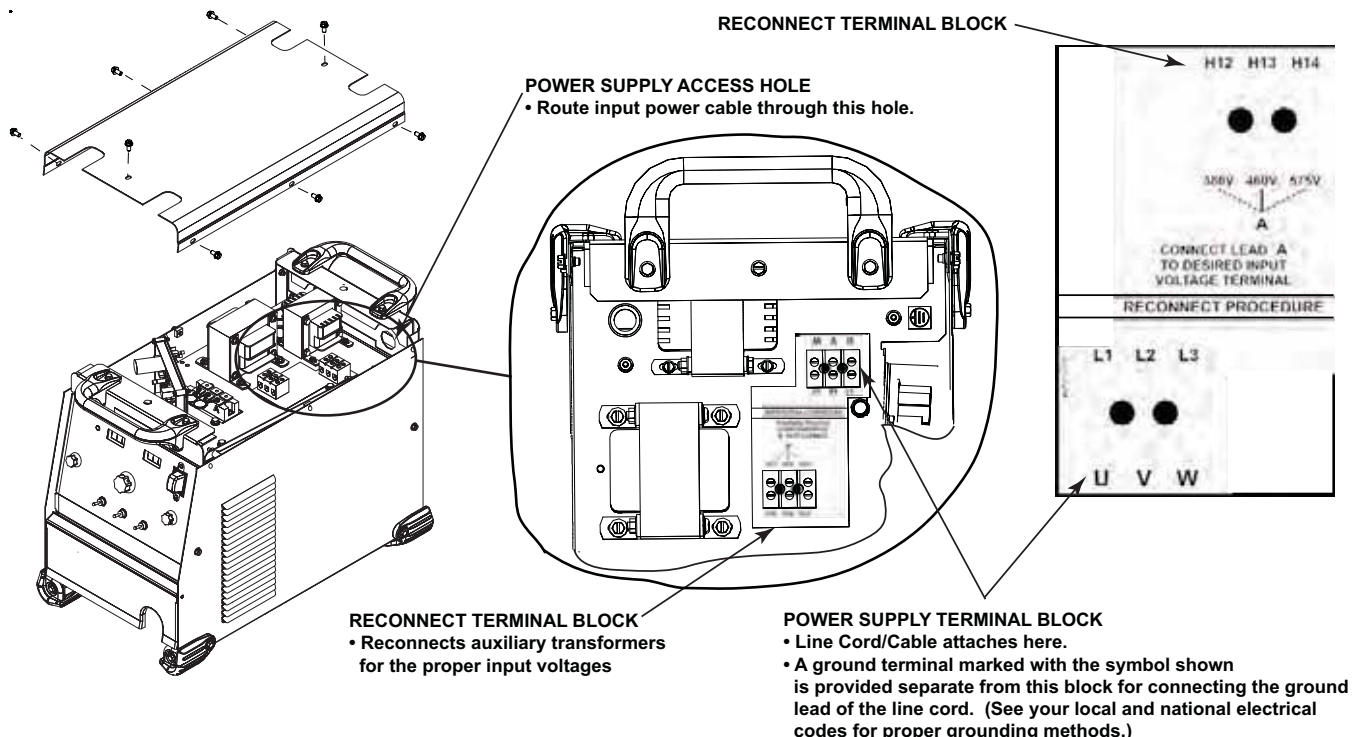
**FIGURE A-1****RECONNECT TERMINAL BLOCK****FX450 (RED-D-ARC)****Red-D-Arc  
Welderrentals.**

**CABLE CONNECTIONS**

See **FIGURE A.2** for locating **6-pin** and **14-pin** connectors on the front of the FX450.

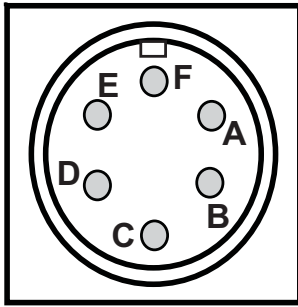

6-PIN REMOTE CONTROL CONNECTOR		
Function	Pin	Wiring
6-pin remote control connector for remote or hand/foot amptrol.	A	77 Remote potentiometer, 5K
	B	76 Remote potentiometer, wiper
	C	75 Remote potentiometer, common
	D	Trigger, common
	E	Trigger, input
	F	Ground

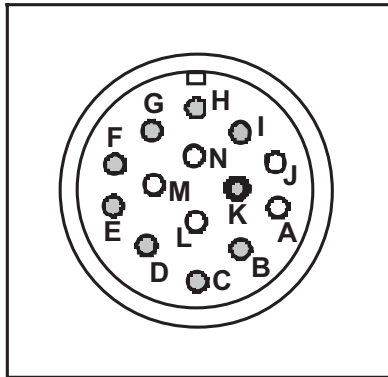

14-PIN CONNECTOR FOR WIRE FEEDER		
Function	Pin	Wiring
14 pin connector for wire feeder connectivity.	A	
	B	Ground
	C	Trigger, Common
	D	Trigger input
	E	77 Remote potentiometer, 5K
	F	76 Remote potentiometer, wiper
	G	75 Remote potentiometer, common
	H	Voltage Sense (21)
	I	Motor (42 VAC)
	J	
	K	Motor (42 VAC)
	L	
	M	
	N	

**FIGURE A.2**

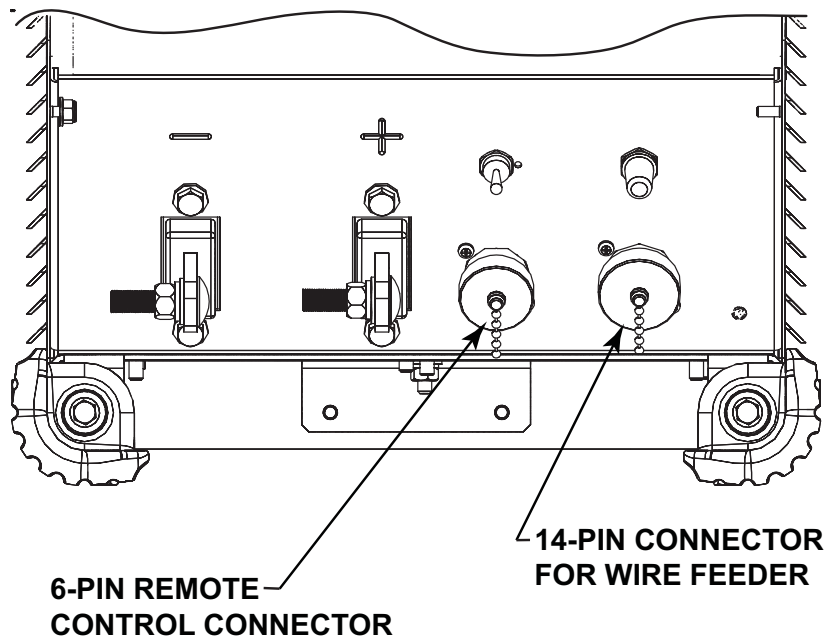

**6-PIN REMOTE CONTROL CONNECTOR**

**14-PIN CONNECTOR FOR WIRE FEEDER**

**FX450 (RED-D-ARC)**

**Red-D-Arc  
Welderrentals.**

## RECOMMENDED ELECTRODE AND WORK CABLE SIZES FOR ARC WELDING

### General Guidelines

Connect the electrode and work cables between the appropriate output studs of the FX450 per the following guidelines:

- Most welding applications run with the electrode being positive (+). For those applications, connect the electrode cable between the wire drive feed plate and the positive (+) output stud on the power source. Connect a work lead from the negative (-) power source output stud to the work piece.
- When negative electrode polarity is required, such as in some Innershield applications, reverse the output connections at the power source (electrode cable to the negative (-) stud, and work cable to the positive (+) stud).

The following recommendations apply to all output polarities and weld modes:

- **Select the appropriate size cables per the “Output Cable Guidelines”** (See Table A.1). Excessive voltage drops caused by undersized welding cables and poor connections often result in unsatisfactory welding performance. Always use the largest welding cables (electrode and work) that are practical, and be sure all connections are clean and tight.

**Note:** Excessive heat in the weld circuit indicates undersized cables and/or bad connections.

- **Route all cables directly to the work and wire feeder, avoid excessive lengths and do not coil excess cable.** Route the electrode and work cables in close proximity to one another to minimize the loop area and therefore the inductance of the weld circuit.

- **Always weld in a direction away from the work (ground) connection.**

## CONTROL CABLE CONNECTIONS

### General Guidelines

Genuine Lincoln control cables should be used at all times (except where noted otherwise). Lincoln cables are specifically designed for the communication and power needs of the FX450. Most are designed to be connected end to end for ease of extension. Generally, it is recommended that the total length not exceed 100 feet (30.5 m). The use of non-standard cables, especially in lengths greater than 25 feet, can lead to communication problems (system shutdowns), poor motor acceleration (poor arc starting), and low wire driving force (wire feeding problems). Always use the shortest length of control cable possible, and DO NOT coil excess cable.

Regarding cable placement, best results will be obtained when control cables are routed separate from the weld cables. This minimizes the possibility of interference between the high currents flowing through the weld cables, and the low level signals in the control cables.

TABLE A.1

OUTPUT CABLE GUIDELINES						
AMPERES	PERCENT DUTY CYCLE	CABLE SIZES FOR COMBINED LENGTHS OF ELECTRODE AND WORK CABLES (RUBBER COVERED COPPER - RATED 167°F or 75°C)**				
		0 to 50Ft. (0 to 15m)	50 to 100Ft. (15 to 30m)	100 to 150 Ft. (30 to 46m)	150 to 200 Ft. (46 to 61m)	200 to 250 Ft. (61 to 76m)
200	60	2	2	2	1	1/0
200	100	2	2	2	1	1/0
250	30	3	3	2	1	1/0
250	40	2	2	1	1	1/0
250	60	1	1	1	1	1/0
250	100	1	1	1	1	1/0
300	60	1	1	1	1/0	2/0
300	100	2/0	2/0	2/0	2/0	3/0
350	40	1/0	1/0	2/0	2/0	3/0
400	60	2/0	2/0	2/0	3/0	4/0
400	100	3/0	3/0	3/0	3/0	4/0
500	60	2/0	2/0	3/0	3/0	4/0

\*\* Tabled values are for operation at ambient temperatures of 104°F(40°C) and below. Applications above 104°F(40°C) may require cables larger than recommended, or cables rated higher than 167°F(75°C).

**SAFETY PRECAUTIONS**

Read this entire section of operating instructions before operating the machine.

**⚠ WARNING**



**ELECTRIC SHOCK can kill.**

- Unless using cold feed feature, when feeding with gun trigger, the electrode and drive mechanism are always electrically energized and could remain energized several seconds after the welding ceases.

- Do not touch electrically live parts or electrodes with your skin or wet clothing.
- Insulate yourself from the work and ground.
- Always wear dry insulating gloves.



**FUMES AND GASES can be dangerous.**

- Keep your head out of fumes.
- Use ventilation or exhaust to remove fumes from breathing zone.

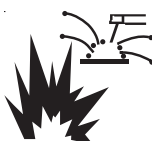

**WELDING SPARKS can cause fire or explosion.**

- Keep flammable material away.
- Do not weld on containers that have held combustibles.



**ARC RAYS can burn.**

- Wear eye, ear, and body protection.

Observe additional guidelines detailed in the beginning of this manual.

**GRAPHIC SYMBOLS THAT APPEAR ON THIS MACHINE OR IN THIS MANUAL**



INPUT POWER



ON



OFF



HIGH TEMPERATURE



CIRCUIT BREAKER



WIRE FEEDER



POSITIVE OUTPUT



NEGATIVE OUTPUT



3 PHASE INVERTER



INPUT POWER



THREE PHASE



DIRECT CURRENT

## GRAPHIC SYMBOLS THAT APPEAR ON THIS MACHINE OR IN THIS MANUAL

$U_0$	<b>OPEN CIRCUIT VOLTAGE</b>
$U_1$	<b>INPUT VOLTAGE</b>
$U_2$	<b>OUTPUT VOLTAGE</b>
$I_1$	<b>INPUT CURRENT</b>
$I_2$	<b>OUTPUT CURRENT</b>
	<b>PROTECTIVE GROUND</b>



**WARNING or CAUTION**



**Explosion**



**Dangerous Voltage**



**Shock Hazard**

## PRODUCT DESCRIPTION

The FX450 is a multi-process CC/CV DC inverter and is rated for 450 amps, 38 volts at a 60% duty cycle. This machine is intended for both factory and field operation. It comes in a compact, rugged case that is designed for portability and outdoor use with an IP23 environmental rating. The user interface of the FX450 is simple and intuitive. Weld modes are selected by a 4 position selector switch. Volts and Amps are displayed on an easy to view LED display, and the amps and volts are set by a large output control knob. A hot start toggle selector switch and an arc control knob allow for finer tuning of the welding arc. The FX450 operates on 380V, 460V, or 575V 50hz or 60hz power.

## DUTY CYCLE

The FX450 is capable of welding at a 100% duty cycle (continuous welding) at 400 amps rated output. The 60% rating is 450 amps base off of a 10 minute cycle - 6 minutes on time and 4 minutes off time. The maximum output of the machine is 500 amps.

The FX450 is also rated for Desert Duty, elevated temperature operation, in a 55°C(131°F) ambient. The machine is output de-rated for this application.

## DESIGN FEATURES

- Severe Duty Design for outdoor use (IP23 rating).
- Passive Power Factor Correction – reliably gives 95% power factor for lower installation costs.
- 89% Efficiency rating – reduces electrical utility costs.
- Simple user interface - designed with the operator in mind. Getting setup for the weld is several clicks away and even the most novice welder can be confident he is setup properly.
- F.A.N. (fan as needed). Cooling fan runs when the output is energized and for a 5 minute cool down period after output is disabled.
- Thermal protection by thermostats with Thermal Indicator LED.
- Error Codes display on LED screen for ease of trouble shooting.
- Electronic over current protection.
- Input voltage misconnection protection.
- Utilizes digital signal processing and microprocessor control.



## RECOMMENDED PROCESSES AND EQUIPMENT

### RECOMMENDED PROCESSES

The FX450 is designed for CC-SMAW, CC-GTAW (lift tig), CV-GMAW, CV-FCAW-SS and CV-FCAW-GS welding processes. CAG (arc gouging) is also supported.

### PROCESS LIMITATIONS

The FX450 is suitable only for the processes listed.

### EQUIPMENT LIMITATIONS

Operating Temperature Range is -10° C to + 55° C.  
Output De-rated at Temperatures above 40°C.

### COMMON EQUIPMENT PACKAGES

Basic Package	
K3073-1	FX450
K2327-5	LF-72 Bench Model
K2149-1	Work Lead Package
K1842-10	10 Ft. Weld Power Cable
3100211	Harris Regulator and gas hose

Common Optional Kits	
K857	Remote Output Control (25 feet)
K857-1	Remote Output Control (100 feet)
K870	Foot Amptrol
K963-3	Hand Amptrol

Compatible Wire Feeders	
All Models	LF-72
	LF-74
	LN-10
	DH-10
	LN-25 Pro

**Note:** The FX450 is not compatible with 115V Wire Feeders.

### CASE FRONT CONTROL DESCRIPTIONS

(See Figure B.1)

1. Power Switch
2. Voltage Display Meter
3. Amperage Display Meter
4. Thermal LED
5. Output Control Dial
6. Weld Process Selector Switch
7. Hot Start Toggle Switch
8. Output Control Local/Remote Toggle Switch
9. Arc Control Dial
10. Weld Terminals On/Remote toggle selector switch
11. Wire feeder voltmeter polarity selection toggle switch
12. Circuit breaker reset button for the 14-pin wire feeder connector
13. 14-pin wire feeder circular connector
14. 6-pin remote circular connector
15. Positive and negative welding output studs

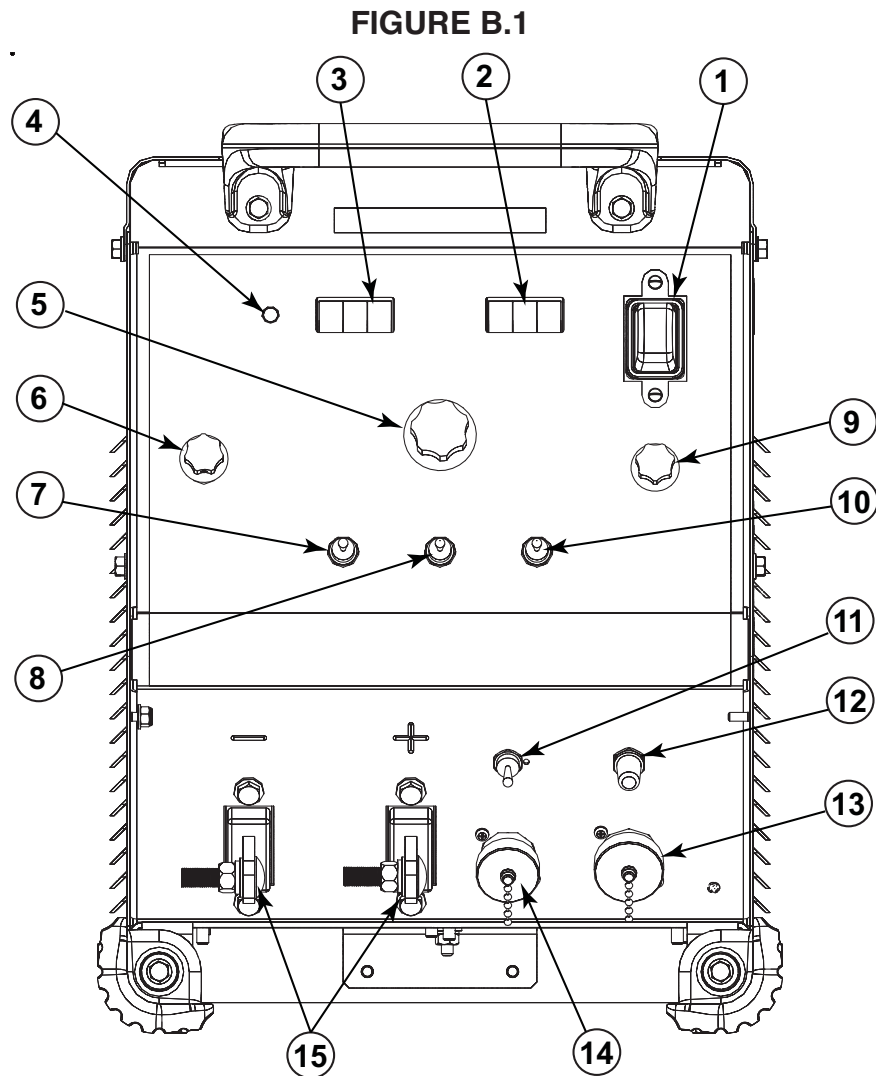

**FX450 (RED-D-ARC)**  
**Red-D-Arc**  
**Welderrentals.**

## CASE BACK CONTROL

(See Figure B.2)

### 1. Input Power Cord Access Hole.

FIGURE B.2

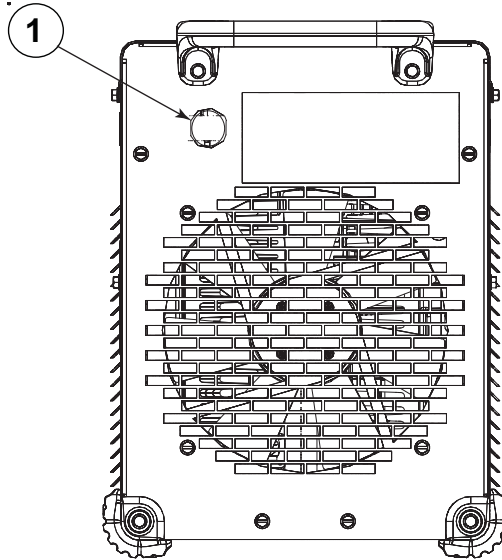

## POWER-UP SEQUENCE

When power is applied to the FX450, the displays will illuminate and display the voltage and/or amperage settings.

## COMMON WELDING PROCEDURES

### ⚠ WARNING

#### MAKING A WELD

The serviceability of a product or structure utilizing the welding programs is and must be the sole responsibility of the builder/user. Many variables beyond the control of The Lincoln Electric Company affect the results obtained in applying these programs. These variables include, but are not limited to, welding procedure, plate chemistry and temperature, weldment design, fabrication methods and service requirements. The available range of a welding program may not be suitable for all applications, and the build/user is and must be solely responsible for welding program selection.

The FX450 is a multi-process inverter welder. The **Weld Process Selector Switch** is used to set the desired weld mode. The FX450 has 4 selectable welding modes:

1. **SMAW** – This is a CC (constant current) weld mode used for the SMAW stick welding process.
2. **GTAW** – This is a CC (constant current) weld mode used for the GTAW TIG welding process.

3. **CV** – This is CV (constant voltage) weld mode used for welding the GMAW MIG welding process and the FCAW-GS, flux cored gas shielded welding process.

4. **CV-Innershield** – This is a CV (constant voltage) weld mode used for welding the FCAW-SS, flux cored self shielded welding process

The FX450 is also capable of gouging. Gouging can be done in either the SMAW mode or the CV and CV-Innershield modes.

In addition to the weld process selector switch, a hot start toggle, output control dial and arc control dial are provided to setup and fine tune the welding procedure.

## WELD CONTROLS AND DISPLAYS

### Weld Process Selector Switch

4 Position switch used to select the welding process.

### Hot Start Toggle Switch

The Hot Start control regulates the starting current at arc initiation. Hot Start can be set to “Off” and no additional current is added at arc start. When set to the “On” position, additional current (relative to the preset current) is added at arc initiation.

### Arc Control Dial

Full range selection of arc control from -10 to +10. In CV mode, this control is an inductance control. In stick mode, the control adjusts the arc force.

### Output Control Dial

Output control is conducted by a single turn potentiometer. (Adjustment is indicated by the meters.) When in Remote Mode, this control sets the maximum welding current of the remote device. For example, full depression of a foot or hand amptrol results in the pre-set level of current.

### Voltage Display Meter

- Prior to CV operation (current flow), the meter displays desired preset voltage value.
- Prior to STICK or TIG operation, the meter displays the Open Circuit Voltage of the Power Source or four dashes if the output has not been turned on.
- During welding, this meter displays actual average volts.
- After welding, the meter holds the actual voltage value for 5 seconds. The displays blink indicating that the machine is in the "hold" period.
- Output adjustment while in the "hold" period results in the "prior to operation" characteristics.

**Amperage Display Meter**

- Prior to STICK or TIG operation (current flow), the meter displays preset current value.
- Prior to CV operation, the meter displays four dashes indicating non-presettable AMPS.
- During welding, this meter displays actual average amps.
- After welding, the meter holds the actual current value for 5 seconds. The displays blink indicating that the machine is in the "hold" period.
- Output adjustment while in the "hold" period results in the "prior to operation" characteristics

**Weld Terminals On/Remote Toggle Switch**

- This switch determines the trigger location.
- When set to the "ON" position, the weld terminals are at OCV (open circuit voltage) and ready to weld.
- When set to the "REMOTE" position, output is enabled through a remote trigger.

**Control - Local/Remote Toggle Switch**

- Set the switch to "Local" to control output at the machine by the Output Control dial.
- Set the switch to "REMOTE" to control output via a remote device (K857 hand amptrol or K870 foot amptrol) connected to the **6-pin** remote connector or a wire feeder connected to the **14-pin** connector.

**Thermal Light**

- This status light indicates when the power source has been driven into thermal overload. If the output terminals were "ON", the output will be turned back on once the unit cools down to an acceptable temperature level. If the unit was operating in the "REMOTE" mode, the trigger will need to be opened before or after the thermal has cleared and closed after the machine has cooled down to an acceptable temperature to establish output.

**BASIC MODES OF OPERATION****SMAW**

This weld mode is a constant current (CC) mode featuring continuous control from 15 – 500 amps. It is intended for the SMAW stick welding processes and arc gouging.

**Hot Start** - The Hot Start control regulates the starting current at arc initiation. Hot Start can be set to "Off" and no additional current is added at arc start. When set to the "On" position, additional current (relative to the preset current) at arc initiation.

**Arc Control** - The Arc Control regulates the Arc Force to adjust the short circuit current. The minimum setting (-10) will produce a "soft" arc and will produce minimal spatter. The maximum setting (+10) will produce a "crisp" arc and will minimize electrode sticking.

**Weld Terminals On/Remote** – Set to "On" so the machine is in the ready to weld state.

**Voltage Display Meter** – This display will display three dashed lines when the machine is in the idle state. This indicates that voltage is not settable in this weld mode. While output is enabled, the actual welding voltage is displayed. After welding, the meter holds the actual voltage value for 5 seconds. Output adjustment while in the "hold" period results in the "prior to operation" characteristics. The displays blink indicating that the machine is in the "hold" period.

**Amperage Display Meter** – This display will display the pre-set welding current when the machine is in the idle state. While output is enabled, the actual weld amperage is displayed. After welding, the meter holds the actual amperage value for 5 seconds. Output adjustment while in the "hold" period results in the "prior to operation" characteristics. The displays blink indicating that the machine is in the "Hold" period.

**Output Control Local/Remote** – When the control is set to local (no remote potentiometer/control plugged into the **6-pin** or **14-pin** connectors), the output is controlled through the Output Control Dial on the front of the FX450. Set this switch to "REMOTE" when an external potentiometer/control is connected.

- When a remote potentiometer is connected, the output control on the FX450 and the remote act as a master/slave configuration. Use the control dial on the FX450 to pre-set the maximum welding current. The remote will control output from minimum to the pre-set maximum.

**Output Control Dial**

- When the Local/Remote is set to **Local**, this dial sets the welding amperage.
- When the Local/Remote is set to **Remote**, this dial sets the maximum welding amperage. The remote potentiometer than controls the amperage from minimum to this pre-set maximum.

**GTAW**

This weld mode is a constant current (CC) mode featuring continuous control from 10 – 500 amps. It is intended for the GTAW TIG welding processes.

**Hot Start** - The Hot Start control regulates the starting current at arc initiation. Hot Start can be set to “Off” and no additional current is added at arc start. When set to the “On” position, additional current (relative to the preset current) at arc initiation.

**Arc Control** – This control is not used in the GTAW mode.

**Weld Terminals On/Remote**

- When set to the “ON” position, the weld terminals are at OCV (open circuit voltage) and ready to weld.
- When set to the “REMOTE” position, output is enabled through a remote trigger.

**Voltage Display Meter** – This display will display three dashed lines when the machine is in the idle state. This indicates that voltage is not settable in this weld mode. While output is enabled, the actual welding voltage is displayed. After welding, the meter holds the actual voltage value for 5 seconds. Output adjustment while in the "hold" period results in the "prior to operation" characteristics. The displays blink indicating that the machine is in the "hold" period.

**Amperage Display Meter** – This display will display the pre-set welding current when the machine is in the idle state. While output is enabled, the actual weld amperage is displayed. After welding, the meter holds the actual amperage value for 5 seconds. Output adjustment while in the "hold" period results in the "prior to operation" characteristics. The displays blink indicating that the machine is in the "hold" period.

**Output Control Local/Remote** – When the control is set to local (no remote potentiometer/control plugged into the **6-pin** or **14-pin** connectors), the output is controlled through the Output Control Dial on the front of the FX450. Set this switch to “REMOTE” when an external potentiometer/control is connected.

- When a remote potentiometer is connected, the output control on the FX450 and the remote act as a master/slave configuration. Use the control dial on the FX450 to pre-set the maximum welding current. The remote will control output from minimum to the pre-set maximum.

**Output Control Dial**

- When the Local/Remote is set to **Local**, this dial sets the welding amperage.
- When the Local/Remote is set to **Remote**, this dial sets the maximum welding amperage.

The remote potentiometer controls the amperage from minimum to this pre-set maximum.

**CV-GAS**

This weld mode is a constant voltage (CV) mode featuring continuous control from 10 to 45 volts.

It is intended for the GMAW, FCAW-GS, MCAW welding processes and arc gouging.

**Hot Start** – Toggle to “ON” position to provide more energy during the start of a weld.

**Arc Control** – The Arc Control regulates pinch effect (Inductance). At the minimum setting (-10), minimizes pinch and results in a soft arc. Low pinch settings are preferable for welding with gas mixes containing mostly inert gases. At the maximum setting (+10), maximizes pinch effect and results in a crisp arc. High pinch settings are preferable for welding FCAW-GS and GMAW with CO<sup>2</sup>.

**Weld Terminals On/Remote**

- When set to the “ON” position, the weld terminals are at OCV (open circuit voltage) and ready to weld. This selection is used for across the arc wire feeders.
- When set to the “REMOTE” position, output is enabled through a remote trigger.

**Amperage Display Meter** – This display will display three dashed lines when the machine is in the idle state. This indicates that amperage is not settable in this weld mode. While output is enabled, the actual welding amperage is displayed. After welding, the meter holds the actual amperage value for 5 seconds. Output adjustment while in the "hold" period results in the "prior to operation" characteristics. The displays blink indicating that the machine is in the "hold" period.

**Voltage Display Meter** – This display will display the pre-set welding voltage when the machine is in the idle state. While output is enabled, the actual weld amperage is displayed. After welding, the meter holds the actual voltage value for 5 seconds. Output adjustment while in the "hold" period results in the "prior to operation" characteristics. The displays blink indicating that the machine is in the "hold" period.

**Output Control Local/Remote** – When the control is set to local (no remote potentiometer/control plugged into the **6-pin** or **14-pin** connectors), the output is controlled through the Output Control Dial on the front of the FX450. Set this switch to “REMOTE” when an external potentiometer/control is connected.

**Output Control Dial**

- When the Local/Remote is set to Local, this dial sets the welding voltage.
- When the Local/Remote is set to Remote, this dial is disabled.

## CV-INNERSHIELD

This weld mode is a constant voltage (CV) mode featuring continuous control from 10 to 45 volts. It is intended for the FCAW-SS welding process and arc gouging.

**Hot Start** – Toggle to “**ON**” position to provide more energy during the start of a weld.

**Arc Control** – The Arc Control regulates pinch effect. At the minimum setting (-10), minimizes pinch and results in a soft arc. At the maximum setting (+10), maximizes pinch effect and results in a crisp arc.

### Weld Terminals On/Remote

- When set to the “**ON**” position, the weld terminals are at OCV (open circuit voltage) and ready to weld. This selection is used for across the arc wire feeders.
- When set to the “**REMOTE**” position, output is enabled through a remote trigger.

**Amperage Display Meter** – This display will display three dashed lines when the machine is in the idle state. This indicates that amperage is not settable in this weld mode. While output is enabled, the actual welding amperage is displayed. After welding, the meter holds the actual amperage value for 5 seconds. Output adjustment while in the "hold" period results in the "prior to operation" characteristics. The displays blink indicating that the machine is in the "hold" period.

**Voltage Display Meter** – This display will display the pre-set welding voltage when the machine is in the idle state. While output is enabled, the actual weld amperage is displayed. After welding, the meter holds the actual voltage value for 5 seconds. Output adjustment while in the "hold" period results in the "prior to operation" characteristics. The displays blink indicating that the machine is in the "hold" period.

**Output Control Local/Remote** – When the control is set to local (no remote potentiometer/control plugged into the **6-pin** or **14-pin** connectors), the output is controlled through the Output Control Dial on the front of the FX450. Set this switch to “**REMOTE**” when an external potentiometer/control is connected.

### Output Control Dial

- When the Local/Remote is set to Local, this dial sets the welding voltage.
- When the Local/Remote is set to Remote, this dial is disabled



## OPTIONS / ACCESSORIES

### General Options

**K2149-1** Work Lead Package.



**K1842-10** 10ft. Weld Power Cable (Lug to Lug).

**Inverter and Wire Feeder Cart** Rear-wheeled cart includes front casters and no-lift gas bottle platform. Convenient handles allow for easy cable storage while full length side trays store parts and tools. Shipped fully assembled. Small footprint fits through 30" (762 mm) door.

**Order K2945-1.**

### Fume Extracting Systems



**Accessory Kit For stick welding.** Includes 35 ft. (10.7 m) 2/0 electrode cable with lug, 30 ft. (9.1 m) 2/0 work cable with lugs, headshield, filter plate, cover plate, work clamp and electrode holder. 400 amp capacity. **Order K704**



### Remote Output Control

**Consists** of a control box with choice of two cable lengths. Permits remote adjustment of output.

**Order K857** for 25 ft. (7.6 m)

**Order K857-1** for 100 ft. (30 m)



### TIG Options

Pro-Torch™ TIG Torches – PTA-9, PTA-17, PTA-26 – 2 piece power cord.



### Foot Amptrol®

Provides 25 ft. (7.6 m) of remote current control for TIG welding. (6-pin plug connection).

**Order K870**



**Hand Amptrol®** - Provides 25 ft. (7.6 m) of remote current control for TIG welding. (6-pin plug connection).

**Order K963-3**



**Arc Start Switch** - May be used in place of the Foot or Hand Amptrol®. Comes with a 25 ft. (7.6m) cable. Attaches to the TIG torch for convenient finger control to start and stop the weld cycle at the current set on the machine.

**Order K814**



**FX450 (RED-D-ARC)**

**Red-D-Arc  
Welderrentals.**



## SAFETY PRECAUTIONS

### WARNING



- ELECTRIC SHOCK can kill.**
- **Only Qualified personnel should perform this maintenance.**
  - **Turn the input power OFF at the disconnect switch or fuse box before working on this equipment.**
- **Do not touch electrically hot parts.**

See additional warning information throughout this Operator's Manual

## VISUAL INSPECTION

Clean interior of machine with a low pressure air stream. Make a thorough inspection of all components. Look for signs of overheating, broken leads or other obvious problems. Many problems can be uncovered with a good visual inspection.

## ROUTINE MAINTENANCE

1. Every 6 months or so the machine should be cleaned with a low pressure airstream. Keeping the machine clean will result in cooler operation and higher reliability. Be sure to clean these areas:
  - All printed circuit boards
  - Power switch
  - Main transformer
  - Heatsink Fins
  - Input rectifier
  - Auxiliary Transformer
  - Reconnect Switch Area
  - Fan (Blow air through the rear louvers)
2. Examine the sheet metal case for dents or breakage. Repair the case as required. Keep the case in good condition to insure that high voltage parts are protected and correct spacings are maintained. All external sheet metal screws must be in place to insure case strength and electrical ground continuity.

## PERIODIC MAINTENANCE

### Thermal Protection

Thermostats protect the machine from excessive operating temperatures. Excessive temperatures may be caused by a lack of cooling air or operating the machine beyond the duty cycle and output rating. If excessive operating temperature should occur, the thermostat will disable the machine output. The meter will remain energized during this time. Thermostats are self-resetting once the machine cools sufficiently. If the thermostat shutdown was caused by excessive output or duty cycle and the fan is operating normally, the Power Switch may be left on and the reset should occur within a 15 minute period.

## HOW TO USE TROUBLESHOOTING GUIDE

### WARNING

Service and Repair should only be performed by Factory Trained Personnel. Unauthorized repairs performed on this equipment may result in danger to the technician and machine operator and will invalidate your factory warranty. For your safety and to avoid Electrical Shock, please observe all safety notes and precautions detailed throughout this manual.

This Troubleshooting Guide is provided to help you locate and repair possible machine malfunctions. Simply follow the three-step procedure listed below.

#### **Step 1. LOCATE PROBLEM (SYMPTOM).**

Look under the column labeled "PROBLEM (SYMPTOMS)". This column describes possible symptoms that the machine may exhibit. Find the listing that best describes the symptom that the machine is exhibiting.

#### **Step 2. POSSIBLE CAUSE.**

The second column labeled "POSSIBLE CAUSE" lists the obvious external possibilities that may contribute to the machine symptom.

#### **Step 3. RECOMMENDED COURSE OF ACTION**

This column provides a course of action for the Possible Cause, generally it states to contact your local Authorized Field Service Facility.

If you do not understand or are unable to perform the Recommended Course of Action safely, contact your local Authorized Field Service Facility.

### CAUTION

If for any reason you do not understand the test procedures or are unable to perform the tests/repairs safely, contact your **Local Authorized Field Service Facility** for technical troubleshooting assistance before you proceed.

Observe all Safety Guidelines detailed throughout this manual

PROBLEMS (SYMPTOMS)	POSSIBLE CAUSE	RECOMMENDED COURSE OF ACTION
<p>Major physical or electrical damage is evident when the sheet metal covers are removed.</p> <p>Machine won't weld, can't get any output.</p>	<p>1. Contact your local authorized Field Service facility for technical assistance.</p> <p>1. If the displays show an Err ### see the fault section for corrective action.</p> <p>2 If the thermal symbol is lit refer to the thermal section.</p> <p>3 If the output terminals are in remote control switch to "ON" and check for output voltage. If output voltage is now present check for correct remote control connection and operation.</p>	<p>1.If all recommended possible areas of misadjustment have been checked and the problem persists, <b>Contact your local Authorized Field Service Facility.</b></p>
<p>Thermal symbol is lit.</p>	<p>1. Check for proper fan operation.</p> <ul style="list-style-type: none"> <li>• Check for material blocking intake or exhaust louvers.</li> <li>• Blow air in the rear louvers to clear dirt from the fan.</li> </ul> <p><b>Note:</b> The Fan As Needed circuitry automatically shuts off the fan 5 minutes after welding has stopped.</p> <p>2. Welding output ratings may have been exceeded. Allow the machine to cool down and reset.</p>	
<p>Wire feeder won't work. Apparently no power to wire feeder</p>	<p>1. Check circuit breakers by the wire feeder receptacles on the rear of the machine. Reset</p> <p>2. Check the control cable between the power source and the wire feeder for continuity.</p>	

 **CAUTION**

If for any reason you do not understand the test procedures or are unable to perform the tests/repairs safely, contact your **Local Authorized Field Service Facility** for technical troubleshooting assistance before you proceed.

**FX450 (RED-D-ARC)**

**Red-D-Arc  
Welderrentals.**

Observe all Safety Guidelines detailed throughout this manual

## USING THE STATUS LED TO TROUBLESHOOT SYSTEM PROBLEMS

Errors are displayed on the user interface. In addition, there are status lights on the control pc board and the switch pc board that contain error sequences.

Included in this section is information about the Status Lights and some basic troubleshooting charts for both machine and weld performance.

The status lights on the main control board and the switch pc board are dual-color LED's. Normal operation for each is steady green.

Error Codes for the FX450			
Error Code#	Description	Corrective Action	
31	Primary Over Current	Check the input power (voltage and frequency). Verify the primary reconnect is properly configured for the input voltage.  If condition persists contact an authorized Field Service Shop.	Machine needs to be turned off and back on to reset.
711	Capacitor over-or-under voltage.	Check input power (voltage and frequency) while welding. Verify the primary reconnect is properly configured for the input voltage.	Machine needs to be turned off and back on to reset.
712	Communication error between P.C. boards or P.C. board fatal.	Re-trigger to recover from error.  If condition persists contact an authorized Field Service Shop.	Weld Terminals Remote: Re-trigger to recover from error.  Weld Terminals Local: Toggle Remote/Local Switch to recover from error.
713	Input Power Misconnect Supply Voltage is too high.	Verify the primary reconnect is properly configured for the input voltage.	Machine needs to be turned off and back on to reset.
714	Input Power Misconnect Supply Voltage is too low.	If condition persists contact an authorized Field Service Shop.	
715	Supply Voltage to the switch Printed Circuit Board is too low.	If condition persists contact an authorized Field Service Shop.	Machine needs to be turned off and back on to reset.

### CAUTION

If for any reason you do not understand the test procedures or are unable to perform the tests/repairs safely, contact your **Local Authorized Field Service Facility** for technical troubleshooting assistance before you proceed.

**FX450 (RED-D-ARC)**

**Red-D-Arc  
Welderrentals.**

WIRING DIAGRAM FX450

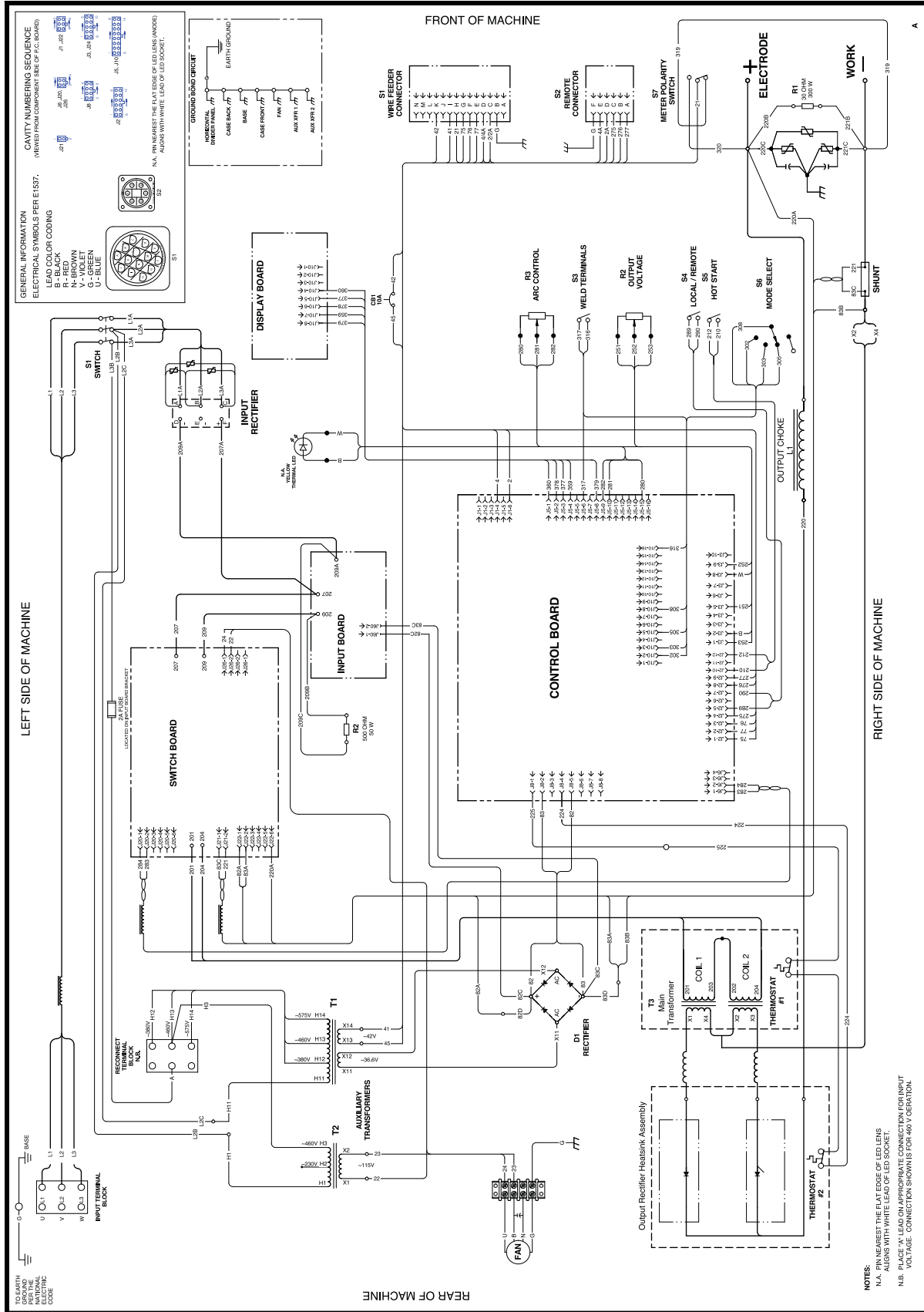

G6890-1

NOTE: This diagram is for reference only. It may not be accurate for all machines covered by this manual. The specific diagram for a particular code is pasted inside the machine on one of the enclosure panels. If the diagram is illegible, write to the Service Department for a replacement. Give the equipment code number.

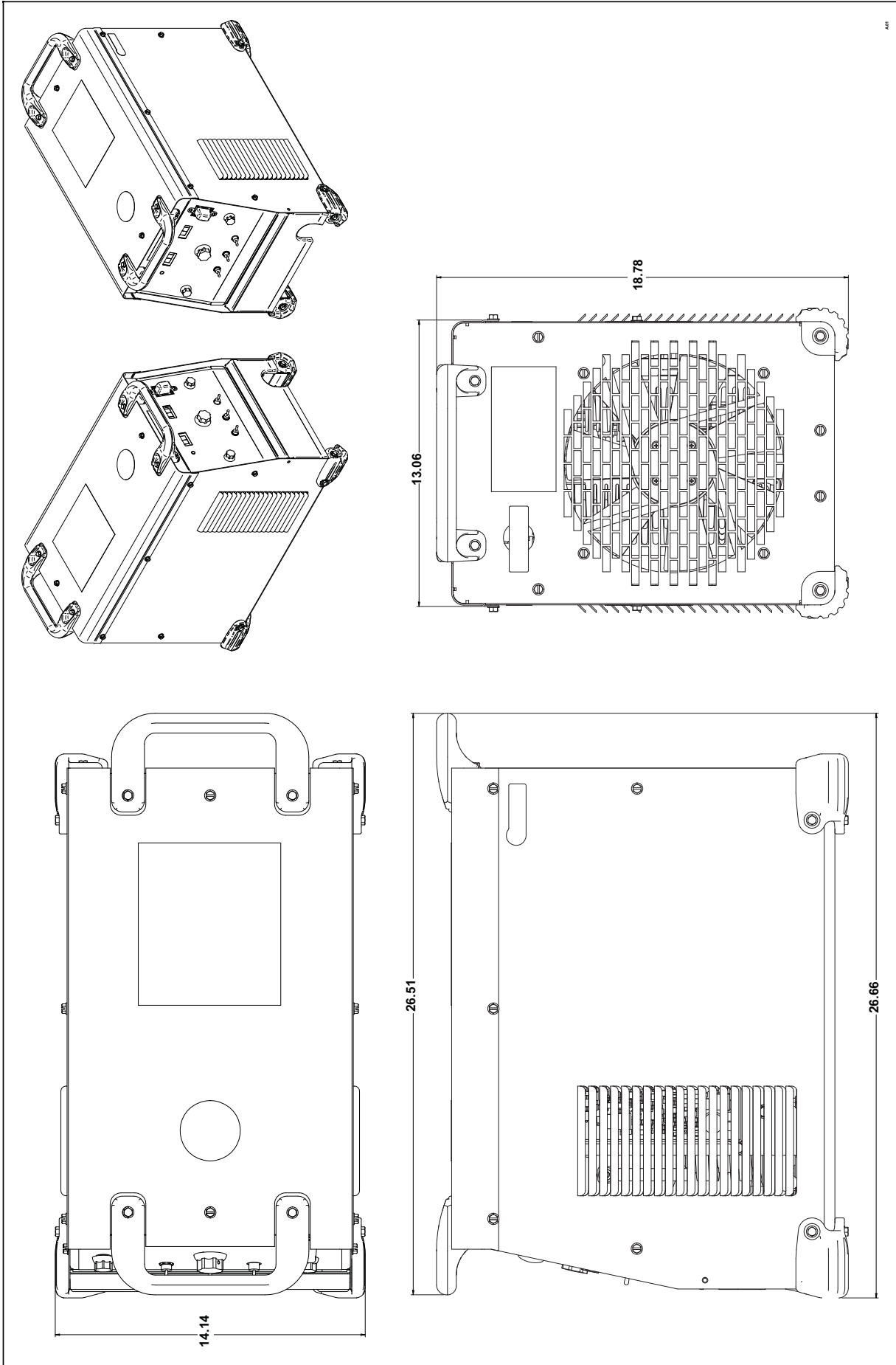

L15698

**FX450 (RED-D-ARC)**  
**Red-D-Arc**  
**Welderrentals.**

			
<b>WARNING</b>	<ul style="list-style-type: none"> <li>Do not touch electrically live parts or electrode with skin or wet clothing.</li> <li>Insulate yourself from work and ground.</li> </ul>	<ul style="list-style-type: none"> <li>Keep flammable materials away.</li> </ul>	<ul style="list-style-type: none"> <li>Wear eye, ear and body protection.</li> </ul>
Spanish <b>AVISO DE PRECAUCION</b>	<ul style="list-style-type: none"> <li>No toque las partes o los electrodos bajo carga con la piel o ropa mojada.</li> <li>Aíslese del trabajo y de la tierra.</li> </ul>	<ul style="list-style-type: none"> <li>Mantenga el material combustible fuera del área de trabajo.</li> </ul>	<ul style="list-style-type: none"> <li>Protéjase los ojos, los oídos y el cuerpo.</li> </ul>
French <b>ATTENTION</b>	<ul style="list-style-type: none"> <li>Ne laissez ni la peau ni des vêtements mouillés entrer en contact avec des pièces sous tension.</li> <li>Isolez-vous du travail et de la terre.</li> </ul>	<ul style="list-style-type: none"> <li>Gardez à l'écart de tout matériel inflammable.</li> </ul>	<ul style="list-style-type: none"> <li>Protégez vos yeux, vos oreilles et votre corps.</li> </ul>
German <b>WARNUNG</b>	<ul style="list-style-type: none"> <li>Berühren Sie keine stromführenden Teile oder Elektroden mit Ihrem Körper oder feuchter Kleidung!</li> <li>Isolieren Sie sich von den Elektroden und dem Erdboden!</li> </ul>	<ul style="list-style-type: none"> <li>Entfernen Sie brennbares Material!</li> </ul>	<ul style="list-style-type: none"> <li>Tragen Sie Augen-, Ohren- und Körperschutz!</li> </ul>
Portuguese <b>ATENÇÃO</b>	<ul style="list-style-type: none"> <li>Não toque partes elétricas e electrodos com a pele ou roupa molhada.</li> <li>Isole-se da peça e terra.</li> </ul>	<ul style="list-style-type: none"> <li>Mantenha inflamáveis bem guardados.</li> </ul>	<ul style="list-style-type: none"> <li>Use proteção para a vista, ouvido e corpo.</li> </ul>
Japanese <b>注意事項</b>	<ul style="list-style-type: none"> <li>● 通電中の電気部品、又は溶材にヒブやぬれた布で触れないこと。</li> <li>● 施工物やアースから身体が絶縁されている様にして下さい。</li> </ul>	<ul style="list-style-type: none"> <li>● 燃えやすいものの側での溶接作業は絶対にしてはなりません。</li> </ul>	<ul style="list-style-type: none"> <li>● 目、耳及び身体に保護具をして下さい。</li> </ul>
Chinese <b>警告</b>	<ul style="list-style-type: none"> <li>● 皮肤或湿衣物切勿接触带电部件及焊缝。</li> <li>● 使你自己与地面和工件绝缘。</li> </ul>	<ul style="list-style-type: none"> <li>● 把一切易燃物品移离工作场所。</li> </ul>	<ul style="list-style-type: none"> <li>● 佩戴眼、耳及身体劳动保护用具。</li> </ul>
Korean <b>위험</b>	<ul style="list-style-type: none"> <li>● 전도체나 용접봉을 젖은 헝겊 또는 피부로 절대 접촉치 마십시오.</li> <li>● 모재와 접지를 접촉치 마십시오.</li> </ul>	<ul style="list-style-type: none"> <li>● 인화성 물질을 접근시키지 마십시오.</li> </ul>	<ul style="list-style-type: none"> <li>● 눈, 귀와 몸에 보호장구를 착용하십시오.</li> </ul>
Arabic <b>تحذير</b>	<ul style="list-style-type: none"> <li>● لا تلمس الاجزاء التي يسري فيها التيار الكهربائي أو الألكترود بجلك الجسم أو بالملابس المبللة بالماء.</li> <li>● ضع عازلا على جسمك خلال العمل.</li> </ul>	<ul style="list-style-type: none"> <li>● ضع المواد القابلة للاشتعال في مكان بعيد.</li> </ul>	<ul style="list-style-type: none"> <li>● ضع أدوات وملابس واقية على عينيك وأذنيك وجسمك.</li> </ul>

READ AND UNDERSTAND THE MANUFACTURER'S INSTRUCTION FOR THIS EQUIPMENT AND THE CONSUMABLES TO BE USED AND FOLLOW YOUR EMPLOYER'S SAFETY PRACTICES.

SE RECOMIENDA LEER Y ENTENDER LAS INSTRUCCIONES DEL FABRICANTE PARA EL USO DE ESTE EQUIPO Y LOS CONSUMIBLES QUE VA A UTILIZAR, SIGA LAS MEDIDAS DE SEGURIDAD DE SU SUPERVISOR.

LISEZ ET COMPRENEZ LES INSTRUCTIONS DU FABRICANT EN CE QUI REGARDE CET EQUIPMENT ET LES PRODUITS A ETRE EMPLOYES ET SUIVEZ LES PROCEDURES DE SECURITE DE VOTRE EMPLOYEUR.

LESEN SIE UND BEFOLGEN SIE DIE BETRIEBSANLEITUNG DER ANLAGE UND DEN ELEKTRODENEINSATZ DES HERSTELLERS. DIE UNFALLVERHÜTUNGSVORSCHRIFTEN DES ARBEITGEBERS SIND EBENFALLS ZU BEACHTEN.



			
<ul style="list-style-type: none"> <li>• Keep your head out of fumes.</li> <li>• Use ventilation or exhaust to remove fumes from breathing zone.</li> </ul>	<ul style="list-style-type: none"> <li>• Turn power off before servicing.</li> </ul>	<ul style="list-style-type: none"> <li>• Do not operate with panel open or guards off.</li> </ul>	<b>WARNING</b>
<ul style="list-style-type: none"> <li>• Los humos fuera de la zona de respiración.</li> <li>• Mantenga la cabeza fuera de los humos. Utilice ventilación o aspiración para gases.</li> </ul>	<ul style="list-style-type: none"> <li>• Desconectar el cable de alimentación de poder de la máquina antes de iniciar cualquier servicio.</li> </ul>	<ul style="list-style-type: none"> <li>• No operar con panel abierto o guardas quitadas.</li> </ul>	Spanish <b>AVISO DE PRECAUCION</b>
<ul style="list-style-type: none"> <li>• Gardez la tête à l'écart des fumées.</li> <li>• Utilisez un ventilateur ou un aspirateur pour ôter les fumées des zones de travail.</li> </ul>	<ul style="list-style-type: none"> <li>• Débranchez le courant avant l'entretien.</li> </ul>	<ul style="list-style-type: none"> <li>• N'opérez pas avec les panneaux ouverts ou avec les dispositifs de protection enlevés.</li> </ul>	French <b>ATTENTION</b>
<ul style="list-style-type: none"> <li>• Vermeiden Sie das Einatmen von Schweißrauch!</li> <li>• Sorgen Sie für gute Be- und Entlüftung des Arbeitsplatzes!</li> </ul>	<ul style="list-style-type: none"> <li>• Strom vor Wartungsarbeiten abschalten! (Netzstrom völlig öffnen; Maschine anhalten!)</li> </ul>	<ul style="list-style-type: none"> <li>• Anlage nie ohne Schutzgehäuse oder Innenschutzverkleidung in Betrieb setzen!</li> </ul>	German <b>WARNUNG</b>
<ul style="list-style-type: none"> <li>• Mantenha seu rosto da fumaça.</li> <li>• Use ventilação e exaustão para remover fumo da zona respiratória.</li> </ul>	<ul style="list-style-type: none"> <li>• Não opere com as tampas removidas.</li> <li>• Desligue a corrente antes de fazer serviço.</li> <li>• Não toque as partes elétricas nuas.</li> </ul>	<ul style="list-style-type: none"> <li>• Mantenha-se afastado das partes moventes.</li> <li>• Não opere com os painéis abertos ou guardas removidas.</li> </ul>	Portuguese <b>ATENÇÃO</b>
<ul style="list-style-type: none"> <li>● ヒュームから頭を離すようにして下さい。</li> <li>● 換気や排煙に十分留意して下さい。</li> </ul>	<ul style="list-style-type: none"> <li>● メンテナンス・サービスに取りかかる際には、まず電源スイッチを必ず切して下さい。</li> </ul>	<ul style="list-style-type: none"> <li>● パネルやカバーを取り外したまま機械操作をしないで下さい。</li> </ul>	Japanese <b>注意事項</b>
<ul style="list-style-type: none"> <li>● 頭部遠離煙霧。</li> <li>● 在呼吸區使用通風或排風器除煙。</li> </ul>	<ul style="list-style-type: none"> <li>● 維修前切斷電源。</li> </ul>	<ul style="list-style-type: none"> <li>● 儀表板打開或沒有安全罩時不準作業。</li> </ul>	Chinese <b>警告</b>
<ul style="list-style-type: none"> <li>● 얼굴로부터 용접가스를 멀리하십시오.</li> <li>● 호흡지역으로부터 용접가스를 제거하기 위해 가스제거기나 통풍기를 사용하십시오.</li> </ul>	<ul style="list-style-type: none"> <li>● 보수전에 전원을 차단하십시오.</li> </ul>	<ul style="list-style-type: none"> <li>● 관널이 열린 상태로 작동치 마십시오.</li> </ul>	Korean <b>위험</b>
<ul style="list-style-type: none"> <li>● ابعء رأسك بعيداً عن الدخان.</li> <li>● استعمل التهوية أو جهاز ضغط الدخان للخارج لكي تبعد الدخان عن المنطقة التي تتنفس فيها.</li> </ul>	<ul style="list-style-type: none"> <li>● اقطع التيار الكهربائي قبل القيام بأية صيانة.</li> </ul>	<ul style="list-style-type: none"> <li>● لا تشغيل هذا الجهاز اذا كانت الاعطية الحديدية الواقية ليست عليه.</li> </ul>	Arabic <b>تحذير</b>

**LEIA E COMPREENDA AS INSTRUÇÕES DO FABRICANTE PARA ESTE EQUIPAMENTO E AS PARTES DE USO, E SIGA AS PRÁTICAS DE SEGURANÇA DO EMPREGADOR.**

使う機械や溶材のメーカーの指示書をよく読み、まず理解して下さい。そして貴社の安全規定に従って下さい。

請詳細閱讀並理解製造廠提供的說明以及應該使用的銀焊材料，並請遵守貴方的有閣勞動保護規定。

이 제품에 동봉된 작업지침서를 숙지하시고 귀사의 작업자 안전수칙을 준수하시기 바랍니다.

اقرأ بتمعن وأفهم تعليمات المصنع المنتج لهذه المعدات والمواد قبل استعمالها واتبع تعليمات الوقاية لصاحب العمل.



• World's Leader in Welding and Cutting Products •

• Sales and Service through Subsidiaries and Distributors Worldwide •

Cleveland, Ohio 44117-1199 U.S.A. TEL: 216.481.8100 FAX: 216.486.1751 WEB SITE: [www.lincolnelectric.com](http://www.lincolnelectric.com)